

OPERATING AND MAINTENANCE INSTRUCTIONS HYDRAULIC ELECTRICAL PUMPS HAM (Manual control)

Part Nr : H A M 7 3 2 2



1. Essential safety requirements.
2. Technical Characteristics.
3. Installation and start up.
4. Maintenance.
5. Problems, malfunctions and solutions.
6. Declaration of Conformity.

- APPENDIX 1 - Hydraulic diagram.
- APPENDIX 2 - Electrical diagram.

LARZEP, S.A.

Avenida Urtiaga, 6
48269 MALLABIA, SPAIN
Tel. +34 943 171200
Fax. +34 943 174166
e-mail: sales@larzep.com
www.larzep.com

LARZEP AUSTRALIA PTY. LTD.

104 Wedgewood Road,
HALLAM, VIC. 3803 AUSTRALIA
Tel. +61 (3) 9796 3744
Fax. +61 (3) 9796 5964
e-mail: sales@larzep.com.au
www.larzep.com.au

LARZEP GB LTD.

3 Commerce Way - Leighton Buzzard
BEDS LU7 4RW UNITED KINGDOM
Tel. +44 1525 377819
Fax. +44 1525 851990
e-mail: sales@larzep.co.uk
www.larzep.co.uk

1. ESSENTIAL SAFETY REQUIREMENTS

1.1 GENERAL CONSIDERATIONS.



LARZEP hydraulic electrical pumps have been specially designed and manufactured in accordance with our quality standards and the controls demanded by the ISO 9001 standard. Nevertheless, improper use may result in the death or serious injury of the user and third parties, as well as causing grave damage to the machine and related materials.

- In light of the above, it is important that the machine should only be used under perfect technical conditions and in accordance with the considerations outlined in this manual. The operator should be aware of the risks inherent in the use of high-pressure hydraulic appliances, familiar with the working of the machine and capable of giving the relevant orders to the personnel working in the area.
- The machine is designed exclusively for the applications described in this manual. **The manufacturer accepts no responsibility for damage resulting from any other application or improper use.**

1.2 ORGANISATIONAL PRINCIPLES

- The operator should have access to the instructions at all times.
- As a complementary precaution, in addition to the instructions manual, the operator should be instructed in the use of the machine and the rules and regulations covering this type of operation, such as those relating to accident prevention and environmental protection, for example.
- All personnel working with the machine must use personal protection equipment:



Boots,

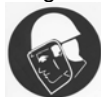

Helmets



Goggles



Gloves and



Protective clothing.

- With the aim of avoiding personal injury or material damage, the operator should receive practical training in the use of the machine, and be aware of and apply the necessary safety measures.
- Each time the machine is used; all personnel should follow the instructions outlined in the 'Start up' section of this instructions manual.
- Never modify the equipment or add elements that affect its safety without the manufacturer's express authorisation.
- Repairs and maintenance operations, etc. should only be carried out by specialist personnel. Always use original Larzep spare parts.
- Replace the flexible hydraulic hoses on a regular basis, even if they show no signs of wear or damage.
- Maintenance operations should be carried out on a regular basis in accordance with the instructions outlined in this manual.
- Once you have finished using the machine, disconnect it, clean it and store it in a clean, safe place.

1.3 GENERAL SAFETY INSTRUCTIONS

- If you notice that the machine or one of the installation's elements is not working properly, stop the operation in process immediately, block the load and then correct the problem.
- Before switching the machine on, make sure that no one is located in the danger zone.
- Check that the machine and its accessories have not been damaged during transportation and installation.
- Use the equipment in a well-light area.
- All the material in the installation should be securely installed and thoroughly stable, and the operator fully aware of all the movements to be carried out during the application.



You should calculate a maximum use of 80% of the machine's nominal capacity. Do not work under the load. If this is absolutely unavoidable, first block the load mechanically.

- Locate the load points in areas of maximum stability, and distribute the load uniformly.



Do not expose equipment to intense heat sources, such as welding, for example. Eliminate pressure and disconnect the machine before carrying out maintenance operations.

- Never, under any circumstances, exceed the machine's nominal capacity. Use indicators to monitor the operating pressure.
- Controls should be used with your hands. Do not use tools or levers, etc. for this purpose. When using tools (to regulate the external limiting valve, for example), make sure you select the correct one and do not use excessive force.
- Clean the machine after use and store in a safe place where there is no risk of damage or dirt.
- Make sure that the plugs and accessories in general are kept perfectly clean. Dirty plugs are difficult to connect and may result in dirt entering the hydraulic circuit.
- Make sure that the flexible hydraulic hoses are not twisted or flattened by loads.
- Make sure that the remote pendant is not activated and that the electro valve is in its standby or neutral position (centre open). When using manual valves, ensure that they are set to position 'C' (centre) before initiating the operation.
- Never trust the load to the pump valves alone. Use safety valves when you wish to stabilise the cylinder pressure, and if possible, block the load mechanically.

2. TECHNICAL FEATURES

Part Nr : HA M 7 3 2 2

2.1 ELECTRIC PUMP WITH MANUAL VALVE

- Useful oil capacity:.....	10 lit.
- Oil flow at 700 bar:	0,36 l/min
- Oil flow at 60 bar.....	4 l/min
- Motor:	Electric
- Power:	0,75 Kw
- Voltage:	230 V. 50/60 Hz. 3 ph.
- Valve ways/Positions:	Manual
	3/3 Single acting Advance/Hold/Retract
- Options:	
Remote pendant (for HAM).....	NO
External protective frame	NO
Set of wheels	NO
Oil cooler	NO

2.2 DESCRIPTION.

The electrical pump consists of the following principal parts:

- Up to 14 liters, aluminium tank with oil level and transport handle.
- From 25 liters on, metal tank with oil level and transport handles.
- 100 liters, metal tank with oil level and eye bolts.
- Up to 14 liters, aluminium lid, support for the entire hydraulic circuit.
- From 25 liters on, metal lid, support for the entire hydraulic circuit.
- Electric motor with corresponding coupling.
- Hydraulic piston pump with filter.
- Transportation plug and ventilation plug (plastic bag), except from 100 liters tank models.
- Pressure meter connection, except from 2 and 4 liters tank models.
- Electrical cabinet or motor circuit breaker box.
- Manual distributing valve or electro valve with 3/8 NPT outputs.
- Internal safety valve adjusted to 700 bar .
- Adjustable external pressure regulating valve: 0-700 bar.



3. INSTALLATION AND START UP

3.1 INSTALLATION

- Read the instructions manual thoroughly and apply the contents.
- Make sure that the machine has not been damaged during transportation and is both clean and complete.
- Position the machine in a stable, well-protected area.
- Use hoses that are long enough to make sure the operator is well away from the danger zone.
- Assemble the complete installation making sure that all accessories (hoses, quick-plugs, valves, joints, pressure meters, distributors, cylinders, etc.) are properly connected. Check without a load as indicated in the next point. A good installation is essential to the proper, risk-free functioning of the machine, and should therefore be carried out by qualified personnel only.
- Connecting the hoses. Operation of the distributing valve:
 - Three-position manual control. Single effect cylinder. Type: HAM __ 2 __.
 - Connect the hose to outlet 'A' (plastic plug). Do not use the connection point marked with an 'X'. This point should remain plugged.
 - When the lever is set to position 'A', the cylinder moves forward. When the lever is in position 'C', it maintains the load in its current position. And when the lever is set to 'T', the cylinder returns, thanks to the action of the spring or the weight of the load itself.
 - Three-position manual control. Double effect cylinder. Type: HAM __ 4 __.
 - Connect the cylinder's forward hose (pressure) to outlet 'A' of the distributing valve, and the return hose to outlet 'B'.
 - When the lever is set to position 'A', the cylinder moves forward. When the lever is in position 'C', it maintains the load in its current position, and when the lever is set to 'B', the cylinder returns, thanks to the pressure applied by the oil distributed by the pump.
- Make sure that the voltage level in the mains coincides with that specified for the machine.

3.2 CHECKING THE CORRECT FUNCTIONING OF ALL MACHINE PARTS

- **Replace the transportation plug with the ventilation plug (supplied in a plastic bag).**
- Check the tank level.
- Connect the mains electricity supply to the terminal strip in the electrical cabinet.
- Make sure that the manual control is set to either 'C' or 'T'.
- Press the electrical cabinet's black button to start the motor.
- Check that the direction of rotation coincides with that indicated by the arrow on the electric motor lid. If the directions do not coincide, stop the motor (by pressing the red switch), and swap the two cables around in the terminal. Repeat the operation and check that the direction of rotation is now correct.
- With HAM-type manual control pumps, press the black button on the circuit breaker box to start the motor. Check the direction of rotation as explained in the previous point.
- Practise moving the piston back and forth.
- With manual control pumps, when the lever is set to position 'A' or 'P', the cylinder piston moves forward once the hose has filled with oil. The piston moves back when the lever is set to position 'B' or 'T'.
- After making sure that no one is located in the danger zone, carefully extend the cylinder as far as it will go.



VERY IMPORTANT:

BEFORE DOING THIS, MAKE SURE THAT THE CYLINDER OR HYDRAULIC TOOL IS DESIGNED TO WITHSTAND ALL THE PRESSURE AT THE END OF ITS STROKE.

- The point of the pressure gauge is only subjected to pressure when the manual control is set to position 'A' or 'B'.
- Use a pressure gauge at this point to check that the internal safety valve is set correctly to 700 bar.
- If you wish to check the pressure of an installation without pressing the remote pendant (open centre, 'P' connected to 'T' and forward and back movements blocked) or with the manual control set to 'C', you should place the pressure gauge and its corresponding joint in the output of the distributing valve.
- If you do not press the remote pendant or the manual valve control is set to 'C', the distributing valve's check valves will maintain the pressure in the circuit.
- If the proposed operating pressure is less than 700 bar, use the external pressure regulator.
- Use a spanner to loosen the lock nut and a screwdriver to loosen (anticlockwise – reduces pressure) or tighten (clockwise – increases pressure) the adjustment screw. Use a pressure gauge to check that the desired operating pressure has been reached, and then block the adjustment screw using the lock nut to prevent unwanted loosening due to vibrations.
- Check for leaks when working under pressure and make sure that the machine and the installation are working correctly in accordance with the established application.
- The above steps should be repeated as many times as necessary, until the operator has become familiar with the working of the machine.

ALL THESE CHECKS SHOULD BE CARRIED OUT WITHOUT A LOAD. THEIR AIM IS TO ENABLE OPERATORS TO BECOME FAMILIAR WITH THE WORKING OF THE MACHINE.

VALVE CHANGE

If you have an equipment with number 4 in the third position of the reference (For example: HAM: _ _ 4_., is it to say, HAM6441) you have an equipment with a valve AZ8400; for double acting cylinders.

If you have a single acting cylinder and you want to use your powerpack with this kind of cylinder you must follow the steps below:

- 1- Remove the 4 screws which join the valve AZ8400 to the powerpack.
- 2- Lift the valve and separate from the lid of the powerpack.
- 3- A pressure inlet hole is located in the center of the lower side of the valve and you can locate 2 hexagonal screws on both sides of the valve.
- 4- One of these screws corresponds to the B outlet, located in the front of the valve; this is the screw which is allocated in the perpendicular to B outlet.
- 5- We have to remove this screw and we get the ball and the spring out.
- 6- Put them away in the bag supplied with the rest of the pieces.
- 7- Take the steel plug supplied with the powerpack in the plastic bag (Code: 15L0021) and put it in the B outlet.
- 8- Place the valve on the powerpack and put the 4 screws.
- 9- In this moment the equipment is ready to work with a single acting cylinder. (A Position: Advance, C Position: Maintains the load, B Position: Return of the cylinder)

If you have an equipment with number 2 in the third position of the reference (For example: HAM: _ _ 2_., is it to say, HAM6421) you have an equipment with a valve AZ8200; for single acting cylinders.

If you have a double acting cylinder and you want to use your powerpack with this kind of cylinder you must follow the steps below:

- 1- Remove the 4 screws which join the valve AZ8200 to the powerpack
- 2- Lift the valve and separate from the lid of the powerpack.
- 3- A pressure inlet hole is located in the center of the lower side of the valve and you can locate 1 hexagonal screw on a side of the valve, and a threaded hole in the other side.
- 4- Take the hexagonal screw supplied in the plastic bag of the valve and place the spring, the retention ball and the copper washer.
- 5- Place the screw with the rest of pieces in the threaded hole.
- 6- Place the valve on the powerpack and put the 4 screws.
- 7- In this moment the equipment is ready to work with a double acting cylinder. (A Position: Advance, C Position: Maintains the load, B Position: Return of the cylinder)

3.3 START UP

- Place the machine in the working zone in such a way as to ensure maximum stability. You should also make sure that the operator is sufficiently far away from the danger zone.
- The operator should check that no one is located in the danger zone and that the machine is in perfect working order and ready to be switched on.
- Start the machine and operate according to the established method.
- With HAM-type manual control pumps, set the valve control to position 'C', stop the motor by pressing the red switch in the circuit breaker box and block the load mechanically if possible. Resolve the problem before resuming operation.
- Once you have finished, check the machine for any possible damage, disassemble it, clean it and store in a safe place.

4. MAINTENANCE

Make sure that the machine is switched off and not under pressure before carrying out any maintenance operation.

Keep the pump clean and in good condition, especially as regards connections, threads, joints and quick plugs, etc.

Use the tank indicator to monitor the oil level. If necessary, top up through the filling plug, using Larzep hydraulic oil (ref. AZ8902)

Electrical connections and their periodic checks should be carried out by fully qualified personnel only. Any loose or damaged cables, etc. should be repaired or replaced immediately.

If you are working in corrosive or aggressive environments, protect the machine accordingly and clean on a regular basis.

Change the oil in the tank regularly – at least once a year if working in dirty environments and/or if the hoses are connected and disconnected frequently.

To change the oil, remove the lid and clean both the tank and the filter, using materials that do not leave residue. When reassembling, use a new tank gasket. Fill the tank with Larzep oil, monitoring the quantity using the level provided.

Do not dump used hydraulic oil. Collect and dispose of it according to the relevant waste disposal regulations.

In the event of a failure or malfunction, all repairs should be carried out by specialist personnel using Larzep spare or replacement parts.

5. PROBLEMS, MALFUNCTIONS AND SOLUTIONS

5.1 OPERATIONS THAT CAN BE CARRIED OUT BY THE USER

5.1.1 The cylinder or hydraulic tool does not move forward.

- Tank under pressure.
 - Replace the transportation plug with the ventilation plug.
- Pump not primed.
 - Turn the machine on without activating the remote pendant / with the distributing control set to 'C' for a few minutes until the pump expels the air from the circuit. This operation can be optimised by stopping and starting the motor. As the pump is gradually primed, the noise made by the machine changes.
 - Not enough oil in the tank.
 - Check level and refill.
- Pressure regulating valve incorrectly adjusted.
 - Readjust the external pressure limiting valve.
- Hose quick plugs not correctly connected.
 - Check that all plugs are connected properly.
- Filter dirty.
 - Remove the lid and proceed as described in the Maintenance section.

All these operations can be carried out by the user. The operations outlined below, on the other hand, should only be carried out by specialist personnel, preferably from an authorised technical assistance service.

5.2 OPERATIONS THAT MUST BE CARRIED OUT BY SPECIALIST PERSONNEL

5.2.1 The cylinder or hydraulic tool does not move forward.

First, check that the problem is not due to a malfunction in the cylinder or hydraulic tool.

- Internal safety valve not properly adjusted.
 - *Readjust or replace (12).*
- Pump's check valve damaged.
 - *Check ball seats (in pump (5) and internal distributor (13)).*
- Pump damaged
 - *Replace (5).*
- Leak in hydraulic circuit
 - *Check circuit and tighten joints.*
- Motor coupling damaged
 - *Replace (10).*
- Electrovalve or manual valve damaged.
 - *Replace distributing valve (4).*

5.2.2 The machine loses pressure when the distributing valve control is set to neutral (position 'C').

- Manual valve check valves damaged.
 - *Check ball seats (4).*

5.2.3 The cylinder or hydraulic tool does not move back.

See point 5.2.1

6. DECLARATION OF CONFORMITY

DECLARACION DE CONFORMIDAD

LARZEP, S.A.
Dirección: Avda. Urtiaga, 6
48269 Mallabia ESPAÑA

E

Declaramos bajo nuestra exclusiva responsabilidad la conformidad de los productos a los que refiere esta declaración, con las disposiciones de la directiva: 89/392/CEE, 91/368/CEE, 93/44/CEE, 93/68/CEE, 98/37/CEE, 2006/42/CE

DECLARATION OF CONFORMITE

Nous, LARZEP, S.A.
Adresse: Avda. Urtiaga, 6
48269 Mallabia SPAIN

F

Déclarons sous notre seule responsabilité que les produits auxquels se réfère cette déclaration sont conformes aux dispositions des Directives: 89/392/EEC, 91/368/EEC, 93/44/EEC, 93/68/EEC, 98/37/EEC, 2006/42/EC

DECLARAÇÃO DE CONFORMIDADE

Nós, LARZEP, S.A.
Endereço: Avda. Urtiaga, 6
48269 Mallabia SPAIN

P

Declaramos, sob nossa única responsabilidade, que os seguintes produtos, incluídos nesta declaração estão em conformidade com o disposto na Directiva: 89/392/EEC, 91/368/EEC, 93/44/EEC, 93/68/EEC, 98/37/EEC, 2006/42/EC

ÖVERENSSTEMMELSESERKLÄRING

Vi, LARZEP, S.A.
Adresse: Avda. Urtiaga, 6
48269 Mallabia SPAIN

DK

Erklærer på eget ansvar, at følgende produkter som er omfattet af denne erklæringen, er i overensstemmelse med bestemmelserne i Direktiv: 89/392/EEC, 91/368/EEC, 93/44/EEC, 93/68/EEC, 98/37/EEC, 2006/42/EC

ERKLÆRING OM OVERENSSTEMMELSE

Vi, LARZEP, S.A.
Adresse: Avda. Urtiaga, 6
48269 Mallabia SPAIN

N

Erklærer på eget ansvar, at følgende produkter som dekkes af denne erklæringen, er i overensstemmelse med bestemmelserne i Direktiv: 89/392/EEC, 91/368/EEC, 93/44/EEC, 93/68/EEC, 98/37/EEC, 2006/42/EC

ÜBEREINSTIMMUNG SERKLÄRUNG

Wir, LARZEP, S.A.
Anschrift: Avda. Urtiaga, 6
48269 Mallabia SPAIN

D

Erklären auf eigene Verantwortung, daß folgende Produkte, auf die sich diese Erklärung bezieht, mit den Bedingungen der Direktiven 89/392/EEC, 91/368/EEC, 93/44/EEC, 93/68/EEC, 98/37/EEC, 2006/42/EC übereinstimmen.

Tipo, Type, Typ, Tyypit.

SM / SH / SP / SMP / SX / SMX / ST / STX / SL / SAM / SAH / SAT / SATGM / SSR / T / TE / TD / D / DH / DDR / DAH / DDA / Z / ZR / W / WP / X / YA / YG / YZ / HAM / HAE / HAZ / HAG / HAS / HM / HE / HG / HZ / HS / HT / WI / CK / CC / CN / FU / FV / FZ / FA / CY / AA / AU / CT / C / KC / LS / LX

A / AB / AC / B / AF / F / HN / DLG / DL / VA / VB / VC / VZ / ECE / ECM / ECZ / EE / EG / EM / EZ / CA / CS

AZ / AP / AV / AS / AT / AX / AY / AM

Mallabia, ESPAÑA 2006 / 11 / 14

Lugar y fecha, place and date, lieu et date, plats och datum, paikka ja päivämäärä, udstedelsessted og-dato, ort und datum, plaats en datum, local e data, luogo e data.

DECLARATION OF CONFORMITY

We, LARZEP, S.A.
Address: Avda. Urtiaga, 6
48269 Mallabia SPAIN

GB

Declare under our sole responsibility that the following products to which this declaration relates conform with the provisions of Directives: 89/392/EEC, 91/368/EEC, 93/44/EEC, 93/68/EEC, 98/37/EEC, 2006/42/EC

DICHIARAZIONE DI CONFORMITÀ

Noi, LARZEP, S.A.
Indirizzo: Avda. Urtiaga, 6
48269 Mallabia SPAIN

I

Dichiariamo sotto la nostra esclusiva responsabilità che i prodotti ai quali questa dichiarazione si riferisce sono conformi quanto previsto dalle Direttive: 89/392/EEC, 91/368/EEC, 93/44/EEC, 93/68/EEC, 98/37/EEC, 2006/42/EC

VAATIMUSTEMUKAISUUSVAKUUTUS.

Me, LARZEP, S.A.
Osoite: Avda. Urtiaga, 6
48269 Mallabia SPAIN

FIN

Vakuutamme yksinomaan omalla vastuullamme, että seuraavat tuotteet, joihin tämä vakuutus liittyy, ovat seuraavien Direktiivien vaatimusten mukaisia: 89/392/EEC, 91/368/EEC, 93/44/EEC, 93/68/EEC, 98/37/EEC, 2006/42/EC

VERKLARING VAN OVEREENKOMST.

Wij, LARZEP, S.A.
Adres: Avda. Urtiaga, 6
48269 Mallabia SPAIN

NL

Verklaren geheel onder eigen verantwoordelijkheid dat de volgende producten, waarop deze verklaring heeft in overeenstemming zijn met de bepalingen van Richtlijn: 89/392/EEC, 91/368/EEC, 93/44/EEC, 93/68/EEC, 98/37/EEC, 2006/42/EC

FÖRSÄKRAN OM ÖVERESSTÄMMELSE

Vi, LARZEP, S.A.
Adress: Avda. Urtiaga, 6
48269 Mallabia SPAIN

S

Försäkrar under eget ansvar att följande produkter som omfattas av denna försäkran är i överensstämmelse med villkoren i Direktiv: 89/392/EEC, 91/368/EEC, 93/44/EEC, 93/68/EEC, 98/37/EEC, 2006/42/EC

LARZEP, S.A.

Nombre y firma, name and signature, nom et signature, namn och underskrift, nimi ja nimikirjoitus, navn og underskrift, name und underskrift, naam en handtekening, nome e assinatura, nome e firma.

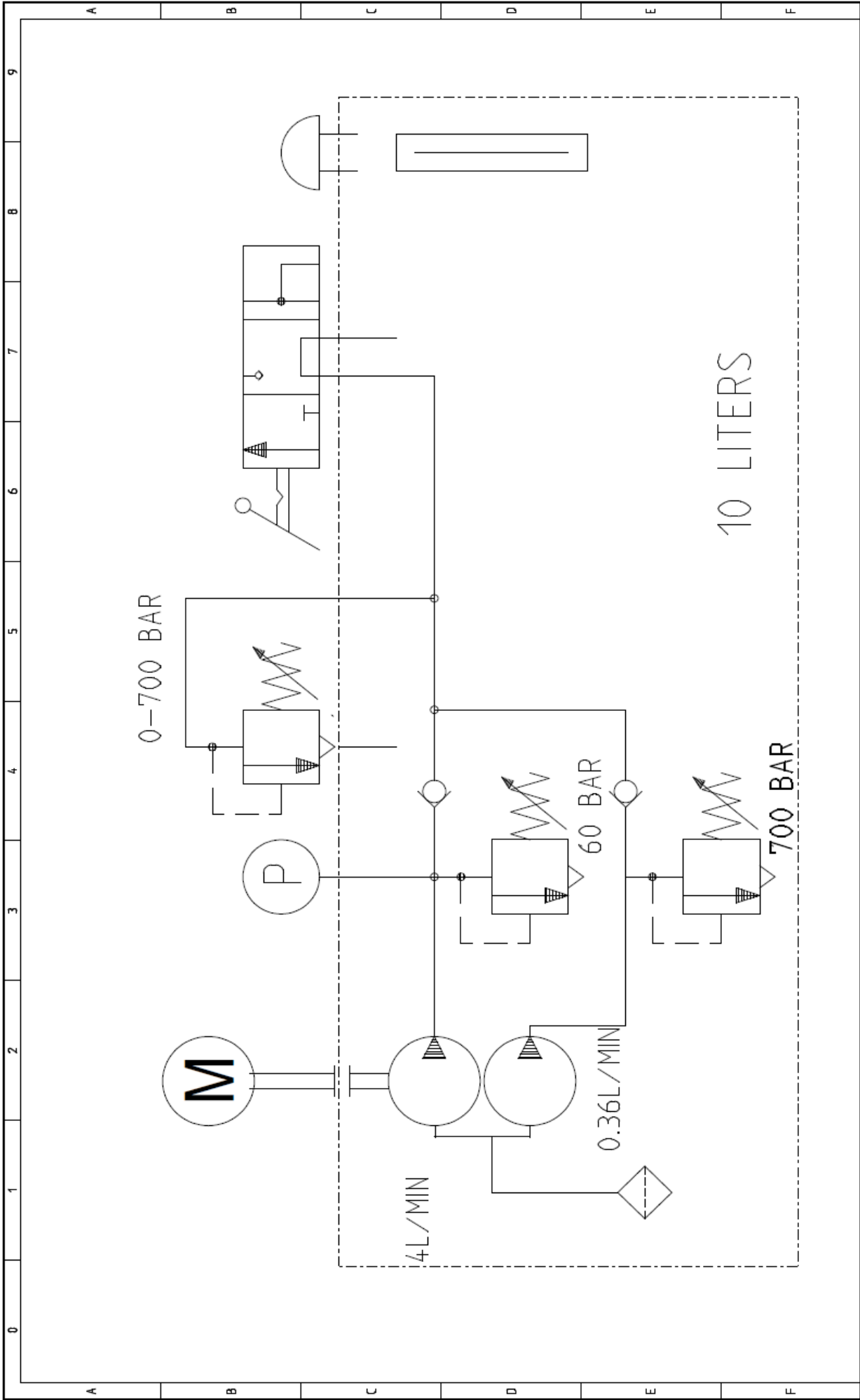

CODIGO: HAM7322		TITULO HOJA: HYDRAULIC DIAGRAM		N. OFERTA:	
Esquema Tipo: Esquemas de circuitos		Pag. .		Total Pag. .	
Fecha	23-09-10	LARZEP HYDRAULIC			
Dibujado	JOSE M	N. OFERTA:			
Comprobado		HYDRAULIC			
Modificacion	Fecha	Nombre			

ANEXOS/ ANNEX

1 ph

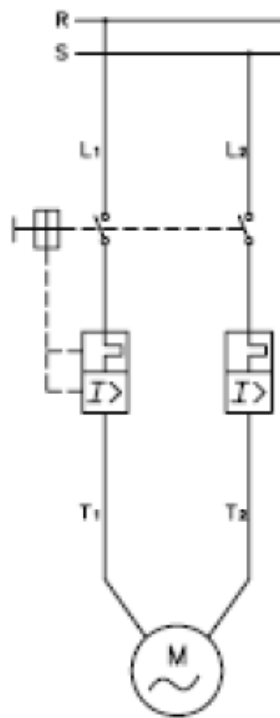

3 ph

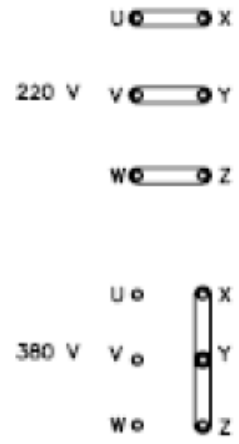
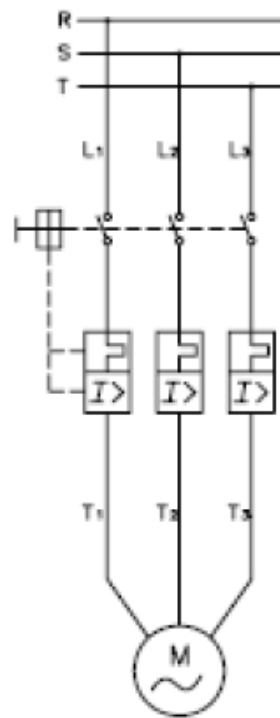

AZE4

