

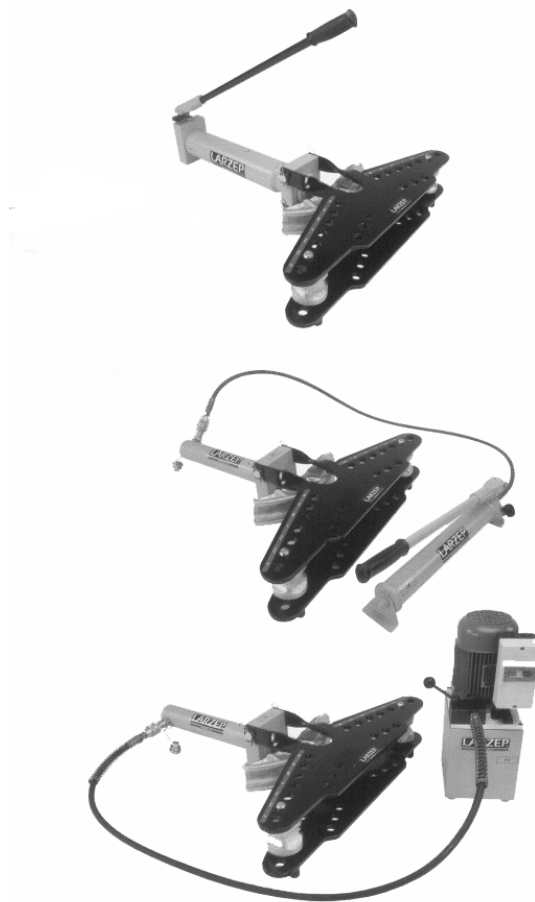

HYDRAULIC BENDER “VC1536” “VA1536”



LARZEP, S.A.
Avenida Urtiaga, 6
48269 MALLABIA, SPAIN
Tel. +34 943 171200
Fax. +34 943 174166
e-mail: sales@larzep.com
www.larzep.com

LARZEP AUSTRALIA PTY. LTD.
104 Wedgewood Road,
HALLAM, VIC. 3803 AUSTRALIA
Tel. +61 (3) 9796 3744
Fax. +61 (3) 9796 5964
e-mail: sales@larzep.com.au
www.larzep.com.au

LARZEP GB LTD.
3 Commerce Way - Leighton Buzzard
BEDS LU7 4RW UNITED KINGDOM
Tel. +44 1525 377819
Fax. +44 1525 851990
e-mail: sales@larzep.co.uk
www.larzep.co.uk

INDEX

1. BEFORE USING THE EQUIPMENT AND SAFETY...2
2. TECHNICAL FEATURES..... 2-3
3. START-UP3
4. MAINTENANCE.....4
5. PROBLEMS AND SOLUTIONS.....4
6. WARRANTY4
7. DECLARATION OF CONFORMITY.....5
ANNEX

- GENERAL DRAWINGS.

1. BEFORE USING THE EQUIPMENT AND SECURITY.

LARZEP hydraulic benders are designed in accordance with internal quality standards, in compliance with the ISO 9001 regulation.

If you find any damage or fault with the product, clearly label it and place it in a location where it will not be available for use until an authorized service dealer has repair the fault.



Never use hydraulic equipment that is damaged or suspected to be in poor conditions.

The tools are designed for the applications described in this manual. Any other use may pose a risk to the equipment and result in hazardous situations for the operator. The manufacturer accepts no responsibility for damage resulting from the improper use of the tool.



Do no store or leave the hydraulic bender where it can be accessed by the children.



The operator should be fully aware of the risks inherent in the use of high-pressure hydraulic tools, and should act responsibility in accordance with that described in this manual, ensuring both his/her own safety as well as the safety of others located in the vicinity of the working zone.



Boots



Helmet



Glasses



Gloves



Clothes

Never modify the tool or add elements that may affect its safety, without express authorisation from the manufacturer.

Before using, check for:

- 1- There are not operators standing around dangerous area.
- 2- Ensure that the equipment it's located over firm template.
- 3- Do not work around dangerous area.
- 4- The commands have been operated with the hands.
- 5- Damaged or dirtied connections or coupler.
- 6- The flexible hydraulic hoses are not twisted.
- 7- The commands are in neutral position.



Check that the working pressure is less than the 80% of nominal capacity

Specialist personnel should only carry out repairs and maintenance operations, etc. Always use original LARZEP spare parts.

Carry out maintenance operations on a regular basis, as indicated in this manual.

Once you have finished using the tool, disconnect it, clean it and store it in a clean, safe place.

2. TECHNICAL FEATURES.

The supplied benders in standard equipments are the ones indicated in the enclosed board below. The obtained radius bending the pipe 90° (long radius benders) is also included

PIPE	INCHES	1/2"	3/4"	1"	1 1/4"	1 1/2"	2"	2 1/2"	3"
	DIAMETER (mm)	21	27	34	42	48	60	75	88
RADIUS		40	60	80	100	115	165	245	290
ANGLE		90	90	90	90	90	90	90	90

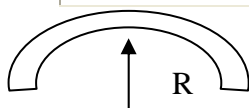

All the models include not only a complete bender seal kit in order to fit them in the piston but also two bending rollers with their corresponding grooves to fit in the pipe.

MODEL	VC1536	VA1536
DESCRIPTION	Bender with cylinder and electro pump	Bender with cylinder and manual pump
CYLINDER	Double acting and spring return. Ref. SM01535.	Double acting and spring return. Ref. SM01535.
PUSH CAPACITY	16 Ton 700 Kg./cm ²	16 Ton 700 Kg./cm ²
PISTON STROKE	355 mm.	355mm.
PUMP	Hydraulic electro pump. Ref.: YAM1112	Hand pump Ref.: W20607
TANK CAPACITY	2 Litres	660 cm ³
OIL DISPLACEMENT	0.35 L/min.	700 Kg./cm ² . 2. Cm ³
POWER	0.37 Kw.220 V. 50Hz 3ph.	-
WEIGHT	75 Kg.	120 Kg

3. START UP.

The bender is packed in a sturdy wooden box, which protects it from the knock damage throughout the transportation. Once the tool is used, clean it and keep it into the box, to be stored until next usage.

Unpack the equipment assuring that all the parts indicated in the drawing provided in the manual are found and the material has not been damaged.

Thread the hydraulic element to the plate of the template. Assembly the upper template by the axle and check that the upper template tilts free.

MODEL VC1536	MODEL VA1536
1- Connect through the hose and the rapid coupler, the electro pump to the cylinder, assuring a perfect connection	1-. Connect trough the hose and the rapid coupler.
2- Substitute the transport plug of the electro-pump by the work plug.	2- Connect the pump to the cylinder, assuring a perfect connection.
3-. Assure that the net voltage corresponds to the machine and that the engine turn is the one marked by the arrow	3- Give some strokes to the pump through the lever with the screw lightly opened (turn to the left) in order to drain the circuit.
4- With the manual distributor control in tank position (lever towards the engine), push the button engine to start up the engine.	4- Close with the hand the screw (turn to the right), after giving some strokes.
5- Assuring that the work area is free and all the parts perfectly fitted put the distributor lever in open position turning 90°.	5- The cylinder will advance.
6- The piston has to advance.	6- Opening again the screw the piston is closed helped by a spring.
7- With the manual distributor control in tank position (lever towards the engine), the piston will return helped by the spring of the cylinder.	

BENDING.

Once we know the pipe to bend dimensions, act in the following way:

- Lift the upper template up to the vertical. (1)
- Set the axle in the hole according to the measure of the pipe as shows the lower template.
- Put the rollers in the axles.
- Place the bender according to the pipe measure in the piston. The short head for pipes up to 1 1/2” and the long head for pipes from 2”.
- Close the upper template fitting all the elements.
- Place the pipe to be bended from the side, between both templates. Maintain the bender in the piston top (2)
- Act over the hydraulic part according to the previous point.
- Let the stroke goes forward only to get the required bending angle, taking into account the elasticity of the pipe. (3)
- Take away pressure from the hydraulic part. The piston will return and it will let the pipe free. Lift the template and remove the pipe. Normally the bender could be pressing the pipe. Use the plastic hammer to separate it. (4)

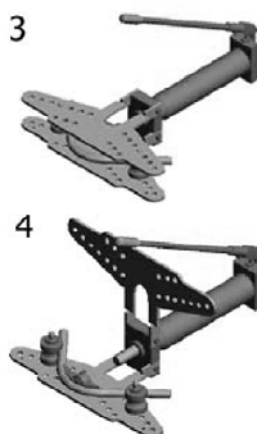
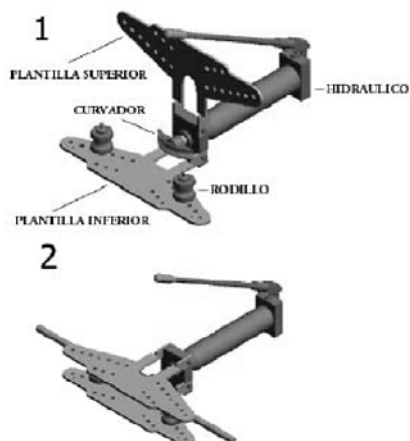

4. MAINTENANCE.

1. Make sure that the machine is switched off and not under pressure before carrying out any maintenance operation
2. Use always original **LARZEP S.A.** parts
3. Check always the equipment visually before using, check the oil level, damage in the hydraulic element (scratched piston, threads, leaks, etc.), accessories situation (hose, rapid coupling, etc.).
4. After using clean always the equipment and keep the critical areas greased threads, axis, rollers inside, piston, etc. before keeping in the case.
5. In case of severe usage, substitute periodically the hoses and the couplings, although they do not seem damaged at first sight.
6. Periodically (minimum once a year), substitute the tank oil by clean oil. Use always **LARZEP S.A.** oil.

MODEL	VC1536	VA1536
OIL FILLING UP	It's made through the plug. Check the oil quantity in the level. Use LARZEP S.A. Ref. AZ8902 oil.	It's made through the plug. . Check the level, placing the pump in vertical and with the head downwards. Use LARZEP S.A. Ref. AZ8901 oil.

5. PROBLEMS, DAMAGES AND SOLUTIONS.

MODEL VC 1535		
PROBLEM	DIAGNOSTIC	SOLUCIÓN
1- Piston does not extend.	- Not enough oil in the pump. - Tank empty. - Prime fewer pumps. - Filter is dirty. - Cylinder pressure retainer damaged. - Pump pressure relief valve unrated. - Wrong hose connection.	1. Check the level and refill up. 2. Clean the work plug. 3. Feed the pump keeping it started some minutes. 4. Remove and clean it properly. 5. Substitute the retainer. 6. Rate again the valve. 7. Check the connection.
2- Cylinder does not reach pressure	- Distribution valve damaged. - Pressure retainer damaged. - Distribution valve damaged. - Leaks by the retaining balls of the pump. - Pressure relief valve unrated.	8. Repair or substitute the valve. See Solution 5. See solution 8. 9. Repair the seat and substitute the balls. See solution 6.
3- Cylinder does not retract.	- Distribution valve ball stacked. - Twisted piston. - Damaged spring.	10. Remove the valve and move the ball. 11. Repair or substitute the piston. 12. Substitute the spring.

MODEL VA 1535		
PROBLEM	DIAGNOSTIC	SOLUTION
1- Piston dos not extend	- Oil lack or excess in the tank. - Dirty filter. - Oil leak by the admission ball in the pump. - Cylinder pressure collar damaged. - Pump cap damaged. - Pressure relief valve unrated. - Hose wrong connection.	1. Check the level and refill up. 2. Remove the pump and clean. 3. Repair the seat and substitute the ball. 4. Substitute the retainer. 5. Substitute the collar. 6. Rate again the valve. 7. Check the connection.
2- Cylinder does not reach pressure.	- Cylinder pressure collar damaged. - Oil leak by the ball of the pump starting up screw. - Oil leak by the retaining ball in the pump.	See Solution 4. See Solution 3. See Solution 3.
3- The cylinder does not retract.	- Starting up screwball stacked. - Piston twisted or damaged. - Damages spring in the cylinder. - Oil excess in the tank.	8. Remove the screw and move the ball. 9. Repair or substitute the piston. 10. Substitute the spring. See Solution 1.

The solutions in black will be carried out by an authorized dealer or specialized staff.

6. WARRANTY.

LARZEP, S.A. guarantees its products against all design and manufacturing defects for the durations of two years from the date of purchase. This guarantee does not include the ordinary wear of both metal and non-metal parts, abuse, using the equipment beyond its rated capacity and any wear or damage incurred as a result of using a hydraulic fluid which is not recommended by **LARZEP, S.A.**

Please note that if the equipment is disassembled or serviced by anyone other than an authorized service dealer or by **LARZEP, S.A.**, this guarantee is rendered null and void.

In the event of a warranty claim, return the equipment, to **LARZEP, S.A.** or the authorized dealer which sold you the hydraulic equipment, **LARZEP, S.A.** will repair or replace the faulty equipment, whichever is deemed most appropriate. **LARZEP, S.A.** shall not be held liable for any consequential damages or losses, which may occur as a result of faulty equipment

7. DECLARATION OF CONFORMITY.**DECLARACION DE CONFORMIDAD**

LARZEP, S.A.
Dirección: Avda. Urriaga, 6
48269 Mallabia ESPAÑA

Declaramos bajo nuestra exclusiva responsabilidad la conformidad de los productos a los que refiere esta declaración, con las disposiciones de la directiva:
89/392/CEE, 91/368/CEE, 93/44/CEE, 93/68/CEE, 98/37/CEE

E**DECLARATION DE CONFORMITE**

Nous, LARZEP, S.A.
Adresse: Avda. Urriaga, 6
48269 Mallabia SPAIN

Déclarons sous notre seule responsabilité que les produits auxquels se réfère cette déclaration sont conformes aux dispositions des Directives:
89/392/EEC, 91/368/EEC, 93/44/EEC, 93/68/EEC, 98/37/EEC

F**DECLARAÇÃO DE CONFORMIDADE**

Nós, LARZEP, S.A.
Endereço: Avda. Urriaga, 6
48269 Mallabia SPAIN

Declaramos, sob nossa única responsabilidade, que os seguintes produtos, incluídos nesta declaração estão em conformidade com o disposto na Directiva:
89/392/EEC, 91/368/EEC, 93/44/EEC, 93/68/EEC, 98/37/EEC

P**ÖVERENSSTEMMELSESERKLÆRING**

Vi, LARZEP, S.A.
Adresse: Avda. Urriaga, 6
48269 Mallabia SPAIN

Erklærer på eget ansvar, at følgende produkter som er omfattet af denne erklæringen, er i overensstemmelse med bestemmelsene i Direktiv:
89/392/EEC, 91/368/EEC, 93/44/EEC, 93/68/EEC, 98/37/EEC

DK**ERKLÆRINGOM ÖVERENSSTEMMELSE**

Vi, LARZEP, S.A.
Adresse: Avda. Urriaga, 6
48269 Mallabia SPAIN

Erklærer på eget ansvar, at følgende produkter som dekkes av denne erklæringen, er i overensstemmelse med bestemmelsene i Direktiv:
89/392/EEC, 91/368/EEC, 93/44/EEC, 93/68/EEC, 98/37/EEC

N**ÜBEREINSTIMMUNGSEKTLÄRUNG**

Wir, LARZEP, S.A.
Anschriřt: Avda. Urriaga, 6
48269 Mallabia SPAIN

Erklären aufeigene Verantwortung, daß folgende Produkte, auf die sich diese Erklärung bezieht, mit den Bedingungen der Direktiven 89/392/EEC, 91/368/EEC, 93/44/EEC, 93/68/EEC, 98/37/EEC übereinstimmen.

D

Tipo, Type, Typ, Tyyppi.

**SM / SH / SP / SMP / SX / SMX / ST / STX / SL / SMA / SHA / SSR / T / TE / TD / D / DH /
DDR / Z / ZR / W / X / YA / YG / YZ / HM / HE / HG / HZ / HS / WI / CK / CC / CN / FU / FV
/ FZ / FA / CY / AA / AU / CT / C / KC**

**A / AB / AC / BL / B / AF / F / HN / DLG / DL / DP / VA / VB / VC / VZ / EC / EE / EG / EM /
EZ / CA / CS**

Mallabia, ESPAÑA 2005 / 04 / 27

Lugar y fecha, place and date, lieu et date, plats och datum, paikka ja päivämäärä, udstedelsessted og-dato, ort und datum, plaats en datum, local e data, luogo e data.

DECLARATION OF CONFORMITY

We, LARZEP, S.A.
Address: Avda. Urriaga, 6
48269 Mallabia SPAIN

Declare under our sole responsibility that the following products to which this declaration relates conform with the provisions of Directives:
89/392/EEC, 91/368/EEC, 93/44/EEC, 93/68/EEC, 98/37/EEC

GB**DICHIARAZIONE DI CONFORMITÀ**

Noi, LARZEP, S.A.
Indirizzo: Avda. Urriaga, 6
48269 Mallabia SPAIN

Dichiariamo sotto la nostra esclusiva responsabilità che i prodotti ai quali questa dichiarazione si riferisce sono conformi quanto previsto dalle Direttive:
89/392/EEC, 91/368/EEC, 93/44/EEC, 93/68/EEC, 98/37/EEC

I**VAATIMUSTEMUKAISUUSVAKUUTUS.**

Me, LARZEP, S.A.
Osoite: Avda. Urriaga, 6
48269 Mallabia SPAIN

Vakuutamme yksinomaan omalla vastuullamme, että seuraavat tuotteet, joihin tämä vakuutus liittyy, ovat seuraavien Direktiivien vaatimusten mukaisia:
89/392/EEC, 91/368/EEC, 93/44/EEC, 93/68/EEC, 98/37/EEC

FIN**VERKLARINGVAN OVEREENKOMST.**

Wij, LARZEP, S.A.
Adres: Avda. Urriaga, 6
48269 Mallabia SPAIN

Verklaren geheel onder eigen verantwoordelijkheid dat de volgende producten, waarop deze verklaring heeft in overeenstemming zijn met de bepalingen van Richtlijn:
89/392/EEC, 91/368/EEC, 93/44/EEC, 93/68/EEC, 98/37/EEC

NL**FÖRSÄKRAN OM ÖVERESSTÄMMELSE**

Vi, LARZEP, S.A.
Adress: Avda. Urriaga, 6
48269 Mallabia SPAIN

Försäkrar under eget ansvar att följande produkter som omfattas av denna försäkran är i överensstämmelse med villkoren i Direktiv:
89/392/EEC, 91/368/EEC, 93/44/EEC, 93/68/EEC, 98/37/EEC

S

LARZEP, S.A.

Nombre y firma, name and signature, nom et signature, namn och underskrift, nimi ja nimikirjoitus, navn og underskrift, name und underskrift, naam en handtekening, nome e assinatura, nome e firma.

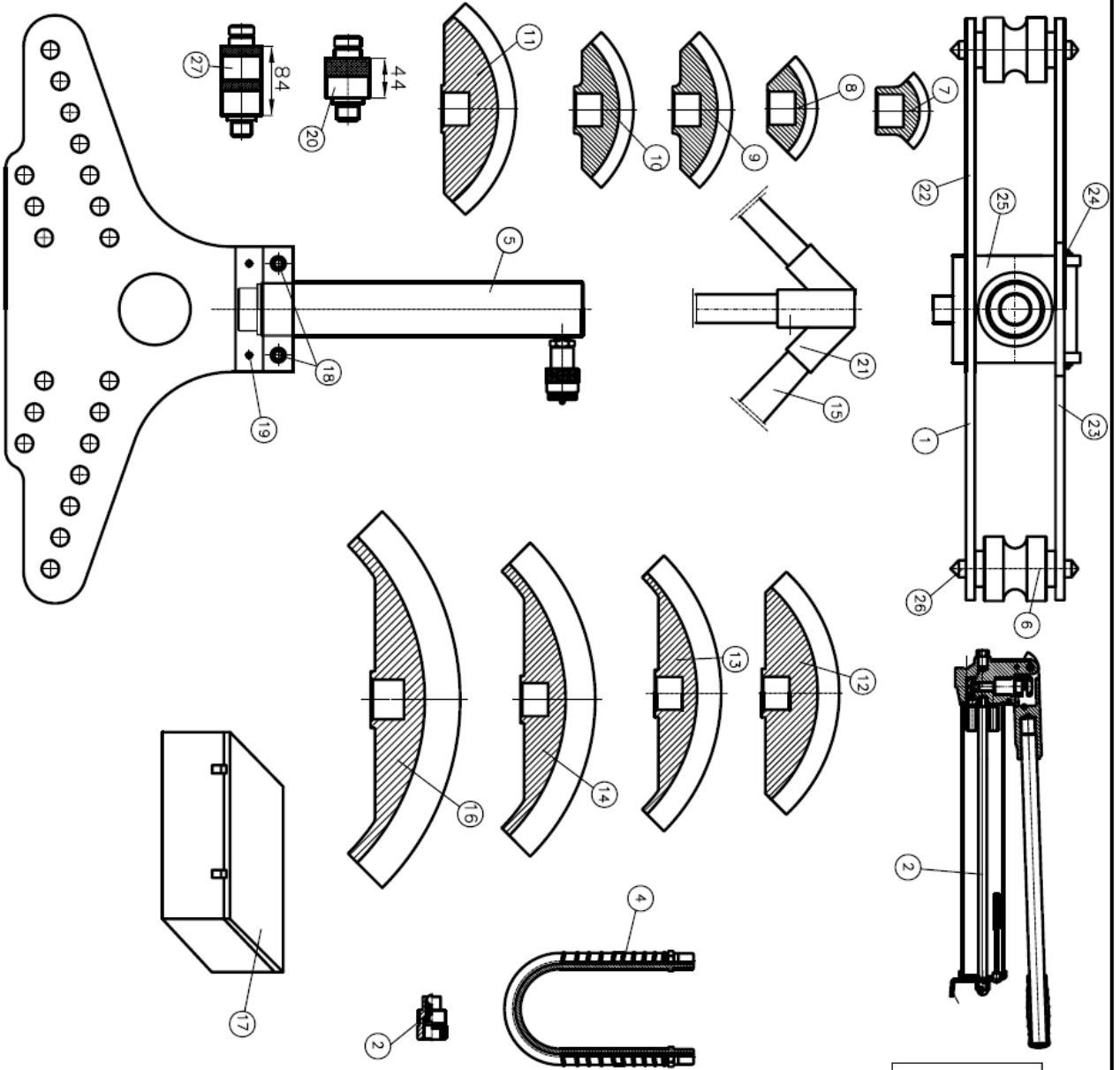

N°	DENOMINACION	CODIGO	N° Piezas
1	PORTE MECANICA	V1536/M	1
2	BOMBA MANUAL	W21407	1
3	ENCHUFE MACHO	AZ3120	1
4	MANGUERA	AP2015	1
5	CILINDRO	SM01535	1

N°	DENOMINACION	CODIGO	N° Piezas
6	RODILLO	24M0055	2
7	CURVADOR 1/2"	24K0544	1
8	CURVADOR 3/4"	24K0545	1
9	CURVADOR 3/8"	24K0593	1
10	CURVADOR 1"	24K0546	1
11	CURVADOR 1 1/4"	24K0547	1
12	CURVADOR 1 1/2"	24K0548	1
13	CURVADOR 2"	24K0549	1
14	CURVADOR 2 1/2"	24K0550	1
15	PATAS TRIPODE	24L0046	3
16	CURVADOR 3"	24K0551	1
17	CAJA DE MADERA	CU3000	1
18	TORNILLO ALLEN M12x35	14A0516	4
19	ESPARRAGO ALLEN MBx10	14F0083	2
20	CABEZA CILINDRO CORTA	56E0090	1
21	TRIPODE	33C0023	1
22	PLANTILLA INFERIOR	24K0542	1
23	PLANTILLA SUPERIOR	24K0543	1
24	EJE GIRO PLANTILLA	15I0354	1
25	PLACA FRONTAL 3"	24K0558	1
26	EJE RODILLO	15I0353	2
27	CABEZA CILINDRO LARGA	56E0091	1

LARZEP
VA1536

N	DENOMINACION	CODIGO	N Piezas
1	PARTE MECANICA	V1536/M	1
2	BOMBA ELECTRICA	HM1224	1
3	ENCHUFE MACHO	AZ3120	1
4	MANGUERA	AP2015	1
5	CILINDRO	SM01535	1

N	DENOMINACION	CODIGO	N Piezas
6	RODILLO	24M0055	2
7	CURVADOR 1/2"	24K0544	1
8	CURVADOR 3/4"	24K0545	1
9	CURVADOR 3/8"	24K0593	1
10	CURVADOR 1"	24K0546	1
11	CURVADOR 1 1/4"	24K0547	1
12	CURVADOR 1 1/2"	24K0548	1
13	CURVADOR 2"	24K0549	1
14	CURVADOR 2 1/2"	24K0550	1
15	PATAS TRIPODE	24L0046	3
16	CURVADOR 3"	24K0551	1
17	CAJA DE MADERA	25C0012	1
18	TORNILLO ALLEN M12x35	14A0516	4
19	ESPARRAGO ALLEN M8x10	14F0083	2
20	CABEZA CILINDRO CORTA	56E0090	1
21	TRIPODE	33C0023	1
22	PLANTILLA INFERIOR	24K0542	1
23	PLANTILLA SUPERIOR	24K0543	1
24	EJE GIRO PLANTILLA	15I0354	1
25	PLACA FRONTAL 3"	24K0558	1
26	EJE RODILLO	15I0353	2
27	CABEZA CILINDRO LARGA	56E0091	1

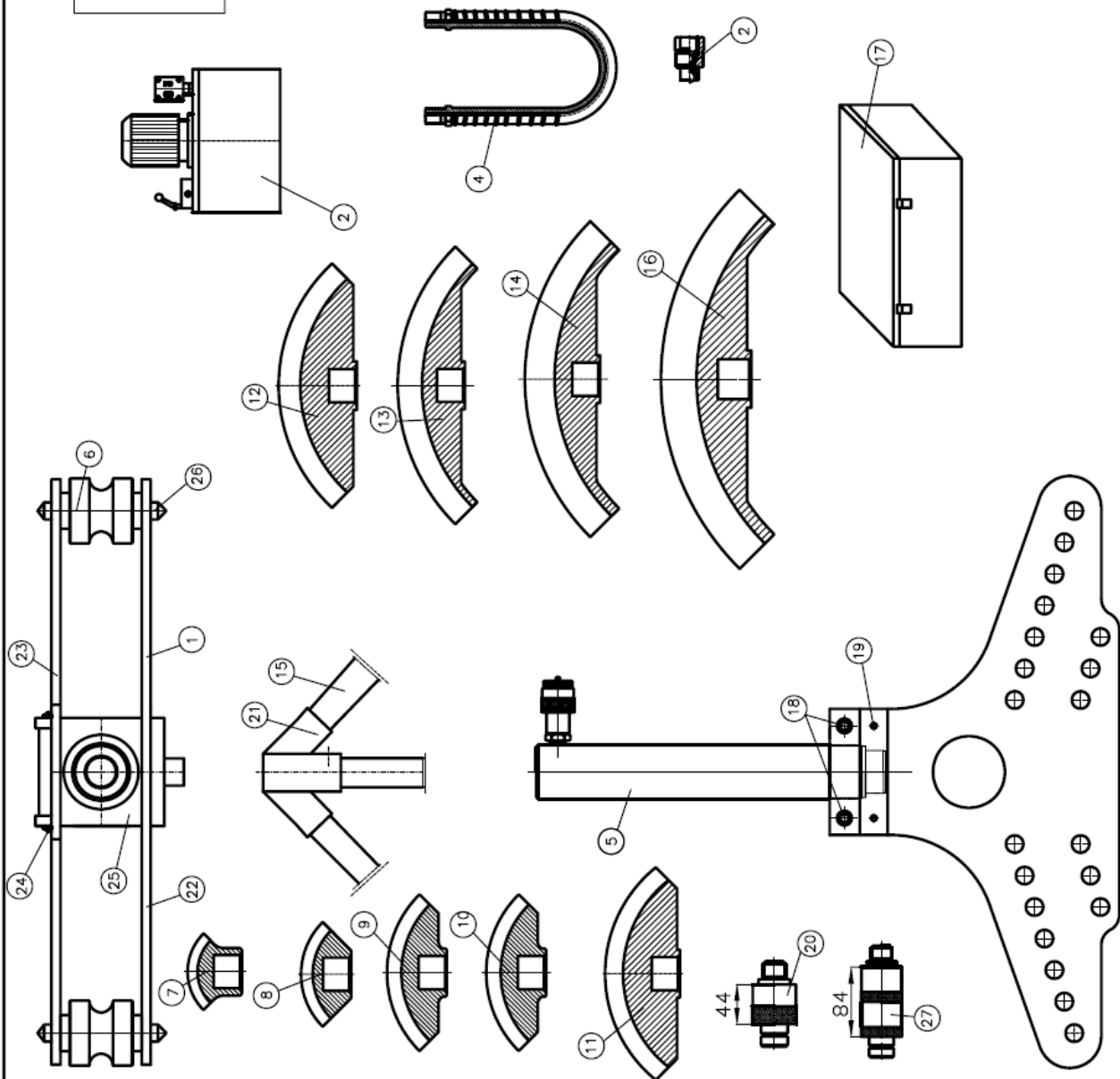

LARZEP
VC1536