



HYDRAULIC BENDER “VC7532”



LARZEP, S.A.

Avenida Urtiaga, 6
48269 MALLABIA, SPAIN

Tel. +34 943 171200

Fax. +34 943 174166

e-mail: sales@larzep.com

www.larzep.com

LARZEP AUSTRALIA PTY. LTD.

104 Wedgewood Road,
HALLAM, VIC. 3803 AUSTRALIA

Tel. +61 (3) 9796 3744

Fax. +61 (3) 9796 5964

e-mail: sales@larzep.com.au

www.larzep.com.au

LARZEP GB LTD.

3 Commerce Way - Leighton Buzzard
BEDS LU7 4RW UNITED KINGDOM

Tel. +44 1525 377819

Fax. +44 1525 851990

e-mail: sales@larzep.co.uk

www.larzep.co.uk

INDEX

1. BEFORE USING THE EQUIPMENT AND SECURITY 2
2. TECHNICAL FEATURES..... 2-3
3. START UP.....3
4. MAINTENANCE.....4
5. PROBLEMS, DAMAGES AND SOLUTIONS4
6. WARRANTY4
7. DECLARATION OF CONFORMITY.....5

ANNEX

❖ GENERAL DRAWING

1. BEFORE USING THE EQUIPMENT AND SECURITY.

LARZEP hydraulic benders are designed in accordance with internal quality standards, in compliance with the ISO 9001 regulation. If you find any damage or fault with the product, clearly label it and place it in a location where it will not be available for use until an authorized service dealer has repair the fault.



Never use hydraulic equipment that is damaged or suspected to be in poor conditions.

The tools are designed for the applications described in this manual. Any other use may pose a risk to the equipment and result in hazardous situations for the operator. The manufacturer accepts no responsibility for damage resulting from the improper use of the tool.



Do no store or leave the hydraulic bender where is can be accessed by the children.



The operator should be fully aware of the risks inherent in the use of high-pressure hydraulic tools, and should act responsibility in accordance with that described in this manual, ensuring both his/her own safety as well as the safety of others located in the vicinity of the working zone.



Boots



Helmet



Glasses



Gloves



Clothes

Never modify the tool or add elements that may affect its safety, without express authorisation from the manufacturer.

Before using, check for:

- 1- There are not operators standing around dangerous area.
- 2- Ensure that the equipment it's located over firm ground.
- 3- Do not work around dangerous area.
- 4- The commands have been operated with the hands.
- 5- Damaged or dirtied connections or coupler.
- 6- The flexible hydraulic hoses are not twisted.
- 7- The commands are in neutral position.



Check that the working pressure is less than the 80% of nominal capacity

Specialist personnel should only carry out repairs and maintenance operations, etc. Always use original LARZEP spare parts.

Carry out maintenance operations on a regular basis, as indicated in this manual.

Once you have finished using the tool, disconnect it, clean it and store it in a clean, safe place.

2. TECHNICAL FEATURES.

The supplied benders in standard equipments are the ones indicated in the enclosed board below. The obtained radius bending the tube 90° (long radius benders) is also included

TUBE	INCHES	1/2"	3/4"	1"	1 1/4"	1 1/2"	2"	2 1/2"	3"	4"	5"	6"
	DIAMETER (mm)	21	27	34	42	48	60	75	88	113	138	164
RADIUS		40	60	80	100	115	165	245	290	550	650	750
ANGLE		90	90	90	90	90	90	90	90	90	90	90

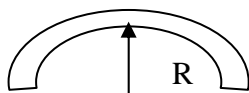

All the models include not only a complete bender seal kit in order to fit them in the piston but also two bending rollers with their corresponding grooves to fit in the tube.

They also include the structure with the upper and lower and also the axles corresponding to the bending rollers.

MODEL	VC7532
DESCRIPTION	BENDER ½"-6" with Electric Pump
CYLINDER	Double acting 75 ton Ref: D07532
CAPACITY	75 ton 700 Kg./cm ²
STROKE	320 mm.
PUMP	Electric HAM7244
TANK CAPACITY	5 Litres
FLOW	0.36 L/min
POWER	0.75 Kw
VOLTAGE	400V.50Hz.3ph
DISTRIBUTOR VALVE	Manual 4 ways 3 positions.
WEIGHT	169 Kg.

3. START UP.

The bender is packed in a sturdy wooden box, which protects it from the knock damage throughout the transportation. Once the tool is used, clean it and keep it into the box, to be stored until next usage.

Unpack the equipment assuring that all the parts indicated in the drawing provided in the manual are found and the material has not been damaged.

The hydraulic part is provided threaded to the structure plate of the grounds. Mount in this plate the lower and upper grounds with the axles and clips. Check that the upper ground tilts free.

MODEL VC7532
1. Connect all the accessories making sure the connection.
2. In the pump, replace the transport plug with the ventilation plug, which is provided with the pump in a plastic bag, check the oil level and make the electric connection.
3. In the pump, connect the hoses of advance of the cylinder in the "A" output of the distributor valve and the hose of return of the cylinder in the "B" output.
4. The lever of the distributor valve must be in "C" position before starting the operation.
5. Push the black switch of the motor circuit breaker box, in order to start the motor and check that the sense of turn is the same than indicated in the motor with an arrow, if the turn was the opposite, change two cables position between itself, in the terminal.
6. With the lever in "A" position the cylinder advances, with the lever is set to position "C" the cylinder maintains the reached pressure and with the lever in position "B" the cylinder returns pushed by the oil of the pump.
7. In order to stop the motor, with the lever of the distributor valve in "C" position, push the red switch of the motor circuit breaker, and block the load mechanically.

BENDING

Once we know the tube to bend dimensions, act in the following way:

1. Lift the upper ground up to the vertical. (1)
2. Put the axles in the holes corresponding to the measure of the tube.
3. Put the rollers in the axles in the position corresponding to the tube to bend. See the marks in the rollers
4. Put the bender corresponding to the tube in the prominent part of the piston.
5. Close the upper ground fitting all the parts.
6. Introduce the tube to bend by a lateral side, between both of the grounds taking care of not turning the rollers from their correct position and maintaining the bender in the piston top (2)
7. Act over the hydraulic part according to what is described in the previous point.
8. Make the piston go outside only the necessary to get the required bending angle, taking into account the elasticity of the tube. (3)
9. Take away pressure from the hydraulic part. The piston will return and it will let the tube free. Lift the ground and remove the tube. Normally the bender could be pressing the tube. Use the plastic hammer to separate it. (4)

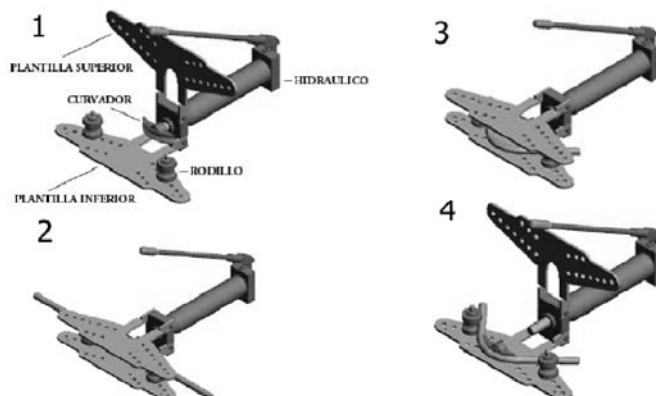

4. MAINTENANCE.

1. Make sure that the machine is switched off and not under pressure before carrying out any maintenance operation
2. Use always original LARZEP S.A. parts
3. Check always the equipment visually before using, check the oil level, damage in the hydraulic element (scratched piston, threads, leaks, etc.), accessories situation (hose, rapid coupling, etc.).
4. After using, clean always the equipment and keep the friction areas greased, such as: threads, axis, rollers inside, piston, etc. before keeping in the case.
5. In case of severe usage, substitute periodically the hoses and the couplings, although they do not seem damaged at first sight.
6. Periodically (minimum once a year), substitute the tank oil by clean oil. Use always LARZEP S.A. oil.
7. Reparation or maintenance actions, in which the mechanic parts must be dismantled (jack, cylinder o pump), will be carried out by specialized staff.

MODEL	VC7532
OIL FILLING (Each 250 hours of using, and unless once a year)	Release the cover and clean the tank and the filter with materials which can not let residues, in when install the cover again replace the tank seal with a new one. Fill the tank with LARZEP oil. Ref. AZ8902

Do not overflow the hydraulic oil to the ground; follow the environmental rules and the rubbish treatment rules.

5. PROBLEMS, DAMAGES AND SOLUTIONS.

MODEL VZ1535		
PROBLEM	POSSIBLE DAMAGE	SOLUTION
1- The piston does not advance.	- Excess or lack of oil.	1. Check the level, and if necessary fill the tank.
	- Obstructed filter.	2. Disassemble the pump and clean.
	- Pressure relief valve do not rated.	3. Rate the valve.
	- Tank pressurized.	4. Replace the transport plug with the ventilation plug.
	- Bad hose connection.	5. Check the connection.
	- Prime fewer pumps.	6. Purge the circuit.
2- The cylinder does not pressurize.	- Internal security valve damaged.	7. Go to your authorized service dealer.
	- Check valve damaged	8. Check the balls seals.
	- Pump damaged	See solution 7.
3- The piston do not retracts.	- Oil leaks.	9. Check the circuit and tighten the couplers.
	- Electro-valve damaged	See solution 7.
	- Piston griped.	9. Repair or replace the piston with a new one.
	- The cylinder's spring damaged.	10. Replace the spring with a new one.

The solutions in black must be carried out by authorized personnel.

6. WARRANTY.

LARZEP, S.A. guarantees its products against all design and manufacturing defects for the durations of two years from the date of purchase. This guarantee does not include the ordinary wear of both metal and non-metal parts, abuse, using the equipment beyond its rated capacity and any wear or damage incurred as a result of using a hydraulic fluid which is not recommended by **LARZEP, S.A.**

Please note that if the equipment is disassembled or serviced by anyone other than an authorized service dealer or by **LARZEP, S.A.**, this guarantee is rendered null and void.

In the event of a warranty claim, return the equipment, to **LARZEP, S.A.** or the authorized dealer which sold you the hydraulic equipment, **LARZEP, S.A.** will repair or replace the faulty equipment, whichever is deemed most appropriate. **LARZEP, S.A.** shall not be held liable for any consequential damages or losses, which may occur as a result of faulty equipment

7. DECLARATION OF CONFORMITY.**DECLARACION DE CONFORMIDAD**

LARZEP, S.A.
Dirección: Avda. Urtiaga, 6
48269 Mallabia ESPAÑA

Declaramos bajo nuestra exclusiva responsabilidad la conformidad de los productos a los que refiere esta declaración, con las disposiciones de la directiva:
89/392/CEE, 91/368/CEE, 93/44/CEE, 93/68/CEE, 98/37/CEE

E**DECLARATION OF CONFORMITY**

Nous, LARZEP, S.A.
Adresse: Avda. Urtiaga, 6
48269 Mallabia SPAIN

Déclarons sous notre seule responsabilité que les produits auxquels se réfère cette déclaration sont conformes aux dispositions des Directives:
89/392/EEC, 91/368/EEC, 93/44/EEC, 93/68/EEC, 98/37/EEC

F**DECLARAÇÃO DE CONFORMIDADE**

Nós, LARZEP, S.A.
Endereço: Avda. Urtiaga, 6
48269 Mallabia SPAIN

Declaramos, sob nossa única responsabilidade, que os seguintes produtos, incluídos nesta declaração estão em conformidade com o disposto na Directiva:
89/392/EEC, 91/368/EEC, 93/44/EEC, 93/68/EEC, 98/37/EEC

P**ÖVERENSSTEMMELSESERKLÄRING**

Vi, LARZEP, S.A.
Adresse: Avda. Urtiaga, 6
48269 Mallabia SPAIN

Erklærer på eget ansvar, at følgende produkter som er omfattet af denne erklæringen, er i overensstemmelse med bestemmelserne i Direktiv:
89/392/EEC, 91/368/EEC, 93/44/EEC, 93/68/EEC, 98/37/EEC

DK**ERKLÆRING OM OVERENSSTEMMELSE**

Vi, LARZEP, S.A.
Adresse: Avda. Urtiaga, 6
48269 Mallabia SPAIN

Erklærer på eget ansvar, at følgende produkter som dekkes av denne erklæringen, er i overensstemmelse med bestemmelserne i Direktiv:
89/392/EEC, 91/368/EEC, 93/44/EEC, 93/68/EEC, 98/37/EEC

N**ÜBEREINSTIMMUNGSERKLÄRUNG**

Wir, LARZEP, S.A.
Anschrift: Avda. Urtiaga, 6
48269 Mallabia SPAIN

Erklären auf eigene Verantwortung, daß folgende Produkte, auf die sich diese Erklärung bezieht, mit den Bedingungen der Direktiven 89/392/EEC, 91/368/EEC, 93/44/EEC, 93/68/EEC, 98/37/EEC übereinstimmen.

D

Tipo, Type, Typ, Tyyppi.

SM / SH / SP / SMP / SX / SMX / ST / STX / SL / SMA / SHA / SSR / T / TE / TD / D / DH /
DDR / Z / ZR / W / X / YA / YG / YZ / HM / HE / HG / HZ / HS / WI / CK / CC / CN / FU / FV
/ FZ / FA / CY / AA / AU / CT / C / KC

A / AB / AC / BL / B / AF / F / HN / DLG / DL / DP / VA / VB / VC / VZ / EC / EE / EG / EM /
EZ / CA / CS

Mallabia, ESPAÑA 2005 / 04 / 27

Lugar y fecha, place and date, lieu et date, plats och datum, paikka ja päivämäärä, udstedelsessted og-dato, ort und datum, plaats en datum, local e data, luogo e data.

DECLARATION OF CONFORMITY

We, LARZEP, S.A.
Address: Avda. Urtiaga, 6
48269 Mallabia SPAIN

Declare under our sole responsibility that the following products to which this declaration relates conform with the provisions of Directives:
89/392/EEC, 91/368/EEC, 93/44/EEC, 93/68/EEC, 98/37/EEC

GB**DICHIARAZIONE DI CONFORMITÀ**

Noi, LARZEP, S.A.
Indirizzo: Avda. Urtiaga, 6
48269 Mallabia SPAIN

Dichiariamo sotto la nostra esclusiva responsabilità che i prodotti ai quali questa dichiarazione si riferisce sono conformi quanto previsto dalle Direttive:
89/392/EEC, 91/368/EEC, 93/44/EEC, 93/68/EEC, 98/37/EEC

I**VAATIMUSTEMUKAISUUSVAKUUTUS.**

Me, LARZEP, S.A.
Osoite: Avda. Urtiaga, 6
48269 Mallabia SPAIN

Vakuutamme yksinomaan omalla vastuullamme, että seuraavat tuotteet, joihin tämä vakuutus liittyy, ovat seuraavien Direktiivien vaatimusten mukaisia:
89/392/EEC, 91/368/EEC, 93/44/EEC, 93/68/EEC, 98/37/EEC

FIN**VERKLARING VAN OVEREENKOMST.**

Wij, LARZEP, S.A.
Adres: Avda. Urtiaga, 6
48269 Mallabia SPAIN

Verklaren geheel onder eigen verantwoordelijkheid dat de volgende producten, waarop deze verklaring heeft in overeenstemming zijn met de bepalingen van Richtlijn:
89/392/EEC, 91/368/EEC, 93/44/EEC, 93/68/EEC, 98/37/EEC

NL**FÖRSÄKRAN OM ÖVERESSTÄMMELSE**

Vi, LARZEP, S.A.
Adress: Avda. Urtiaga, 6
48269 Mallabia SPAIN

Försäkrar under eget ansvar att följande produkter som omfattas av denna försäkran är i överensstämmelse med villkoren i Direktiv:
89/392/EEC, 91/368/EEC, 93/44/EEC, 93/68/EEC, 98/37/EEC

S

LARZEP, S.A.

Nombre y firma, name and signature, nom et signature, namn och underskrift, nimi ja nimikirjoitus, navn og underskrift, name und underskrift, naam en handtekening, nome e assinatura, nome e firma.

GENERAL DRAWING: BENDER

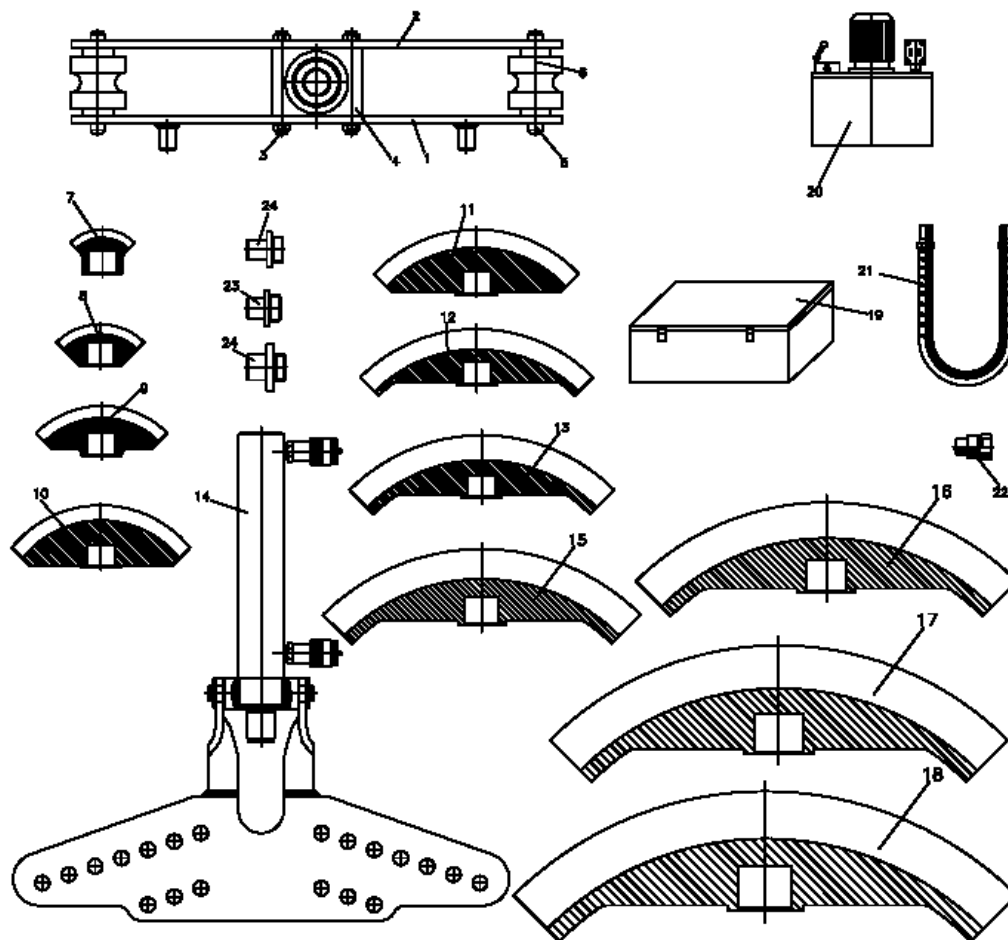

N°	DENOMINACION	CODIGO	N° Piezas
1	PLANTILLA INFERIOR	24K0252	1
2	PLANTILLA SUPERIOR	24K0253	1
3	EJES FIJACION CHASIS CON 4 TUERCAS	15I0270	1
4	CABEZA FIJACION CHASIS, CON 2 EJES GUM	24K0259	1
5	EJE	15I0271	2
6	RODILLO	24M0044	2
7	CURVADOR 1/2"	24K0241	1
8	CURVADOR 3/4"	24K0242	1
9	CURVADOR 1"	24K0243	1
10	CURVADOR 1 1/4"	24K0244	1
11	CURVADOR 1 1/2"	24K0245	1
12	CURVADOR 2"	24K0246	1
13	CURVADOR 2 1/2"	24K0247	1

14	CILINDRO 75Tm	D07532	1
15	CURVADOR 3"	24K0248	1
16	CURVADOR 4"	24K0249	1
17	CURVADOR 5"	24K0250	1
18	CURVADOR 6"	24K0251	1
19	CAJA DE MADERA	25C0008	1
20	BOMBA ELECTRICA	YAM1242	1
21	MANGUERA	AP2015	2
22	ENCHUFE MACHO	AZ3120	2
23	ACOPLAMIENTO CILINDRO	56E0062	1
24	ACOPLAMIENTO CILINDRO	56E0063	1
25	ACOPLAMIENTO CILINDRO	56E0068	1

Cuatro orificios 1/2-13 profundidad 18mm

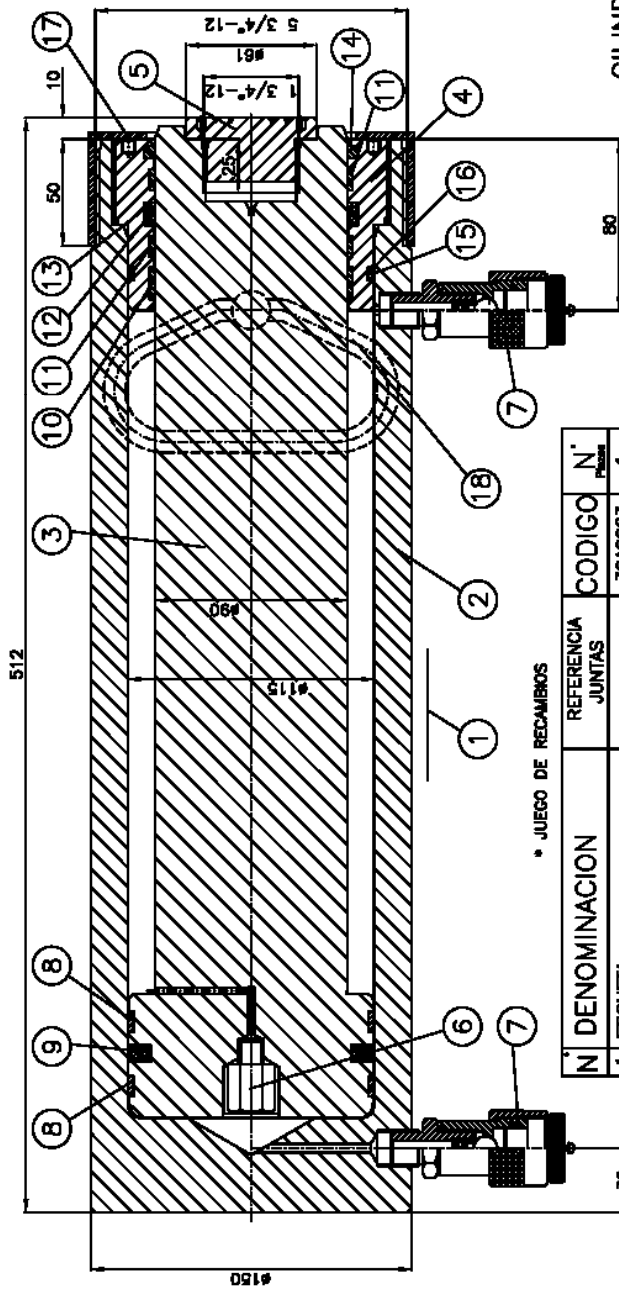
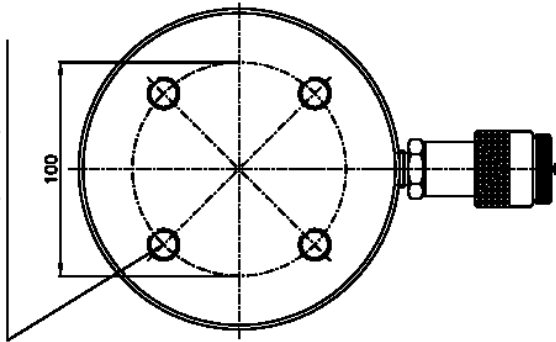

* JUEGO DE RECAMBIOS

CILINDRO DOBLE EFECTO

Ref. Comercial: D07532

CAPACIDAD EMPUJE 72.7Tm (713.02 kN)
 CAPACIDAD TRACCION 14.088 Tm (138.06 kN)
 PRESION 700 Kg/Cm²
 ALTURA CERRADO 512 mm
 CARRERA 320 mm
 AREA 103.86 Cm²
 VOLUMEN 3323.8 cm³
 PESO 61 Kg

N°	DENOMINACION	REFERENCIA JUNTAS	CODIGO	N°
1	ETIQUETA		30A0023	1
2	CUERPO		52F0199	1
3	EMBOLO		53F0231	1
4	GUIA		55F0101	1
5	CABEZA		58F0018	1
6	VALVULA SEGURIDAD T.350Kg/Cm ²		17C0001	1
7	ENCHUFE HEMBRA G.C		AZ3140	2
* 8	ARO GUIA #115x#110x8.7	GF6901150-C390	58F0172	2
* 9	JUNTA DE PISTON #115x#94x8.1	PT0401150-T46N	12B0257	1
* 10	ARO GUIA #90x#95x15	GR7300900-C380	58F0067	1
* 11	ARO GUIA #90x#95x9.7	GR6900600-C390	58F0170	2
* 12	COLLARIN #90x#100x8	TTU 90-100/2	12B0258	1
* 13	SEGMENTO		57A0327	1
* 14	RASCADOR #90x#100x6	WD2200900-#1J403	12H0077	1
* 15	TORICA #107.54x3.53		12A0029	1
* 16	SEGMENTO		57A0357	1
17	PROTECTOR ROSCA		12L0020	1
18	ASA		33C0005	2